



Repairs Guide

Contents

Baths and showers.....	3
Doors –external.....	4
Doors –dry riser.....	5
Doors –fittings.....	6
Doors –garages.....	7
Doors –internal.....	8
Doors –locks.....	9
Drainage.....	10
Electrics.....	11
Externals.....	12
Floors, walls and ceilings.....	13
Glazing.....	14
Gutters.....	15
Heating and hot water.....	16
Kitchen units.....	17
Roofs.....	18
Sinks and basins.....	19
Stairs.....	20
Toilets.....	21
Water services.....	22
Windows –timber.....	23
Windows –metal.....	24
Windows –/aluminium.....	25

When reporting a repair, simply call our maintenance team on 020 8554 1009.

This information booklet has been produced to provide you with an ease of mind when reporting a repair.



Bath and Showers

What is the fault and it's number?

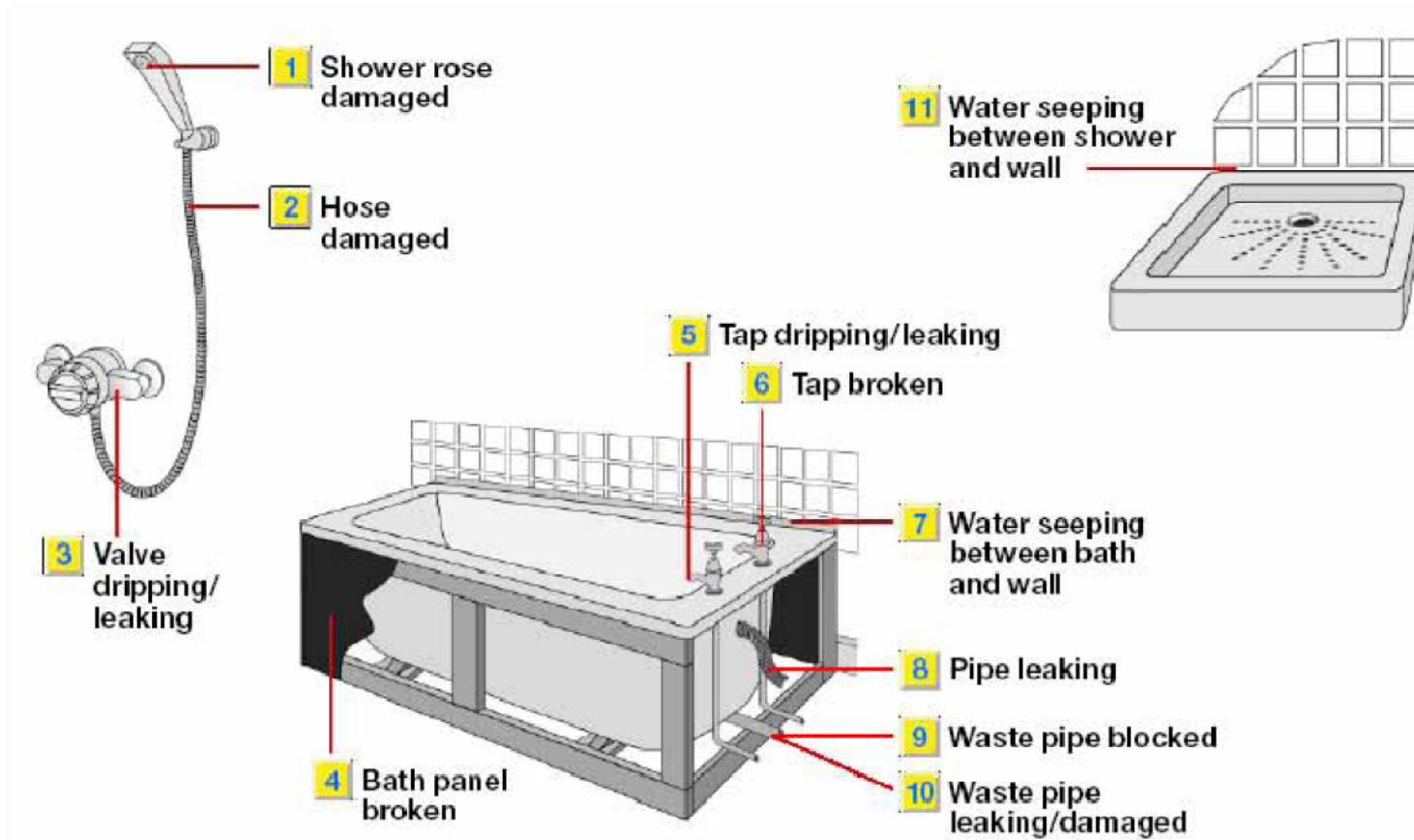

When reporting a repair, simply call our maintenance team on 020 8554 1009.

This information booklet has been produced to provide you with an ease of mind when reporting a repair.



Doors - External

What is the fault and it's number?

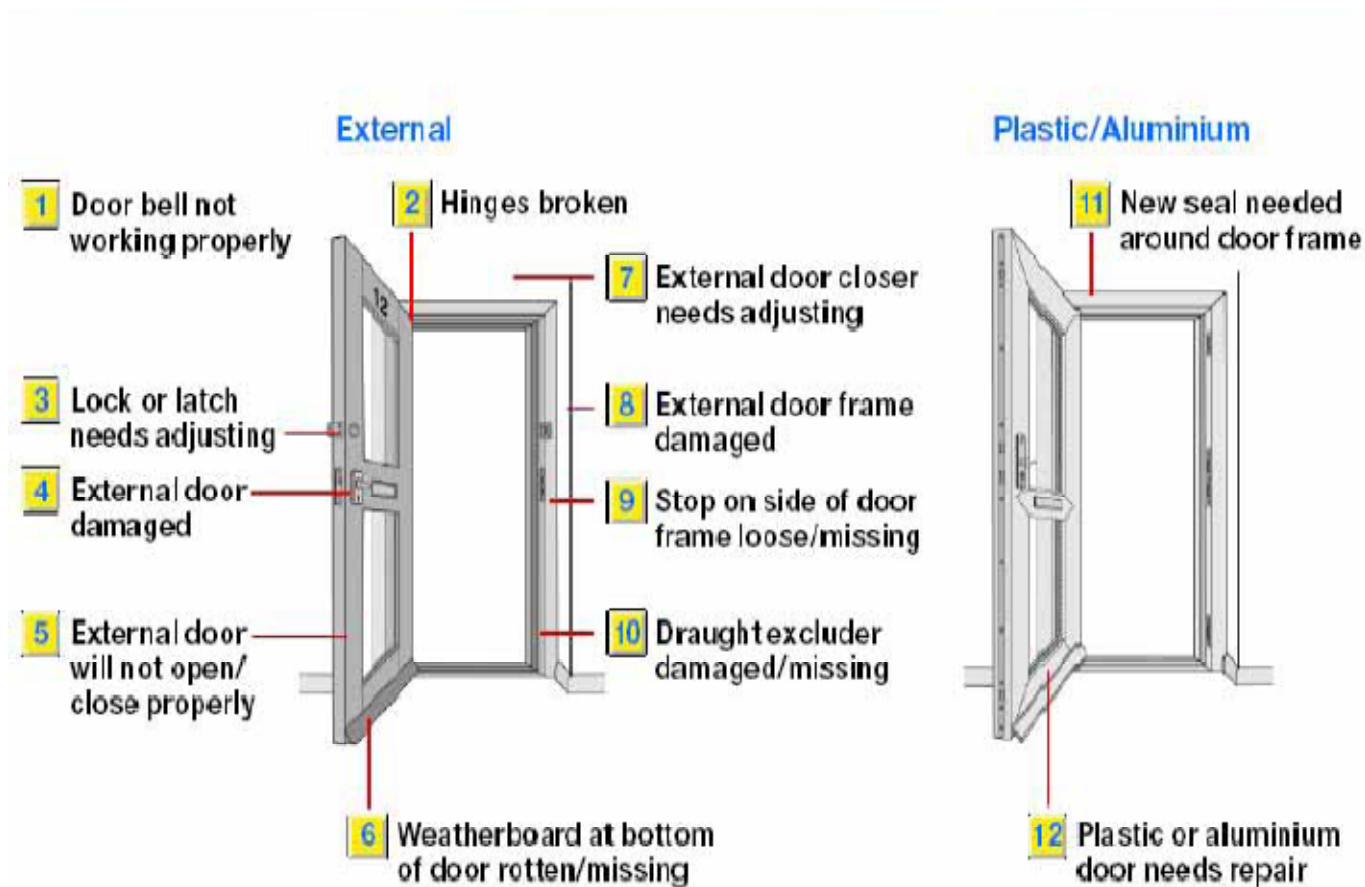

When reporting a repair, simply call our maintenance team on 020 8554 1009.

This information booklet has been produced to provide you with an ease of mind when reporting a repair.



Doors – Dry Riser

What is the fault and it's number?

6 Loft access needs repair

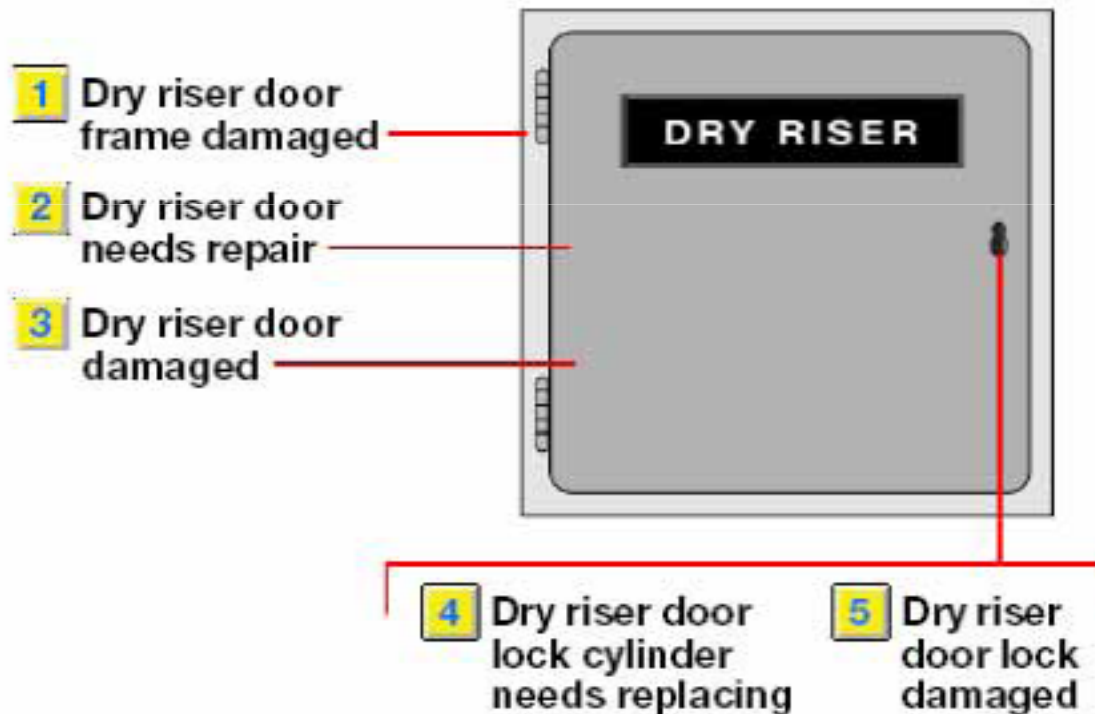

When reporting a repair, simply call our maintenance team on 020 8554 1009.

This information booklet has been produced to provide you with an ease of mind when reporting a repair.



Doors – Fittings

What is the fault and it's number?

1 Door handle broken

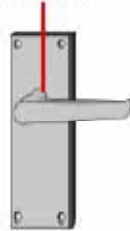

2 Internal door lock/latch broken



3 Closer on side of door broken

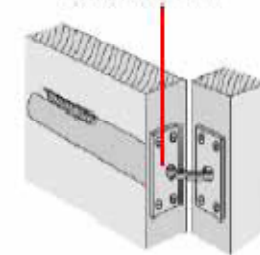

4 Cupboard hinge broken



5 Door hinge broken

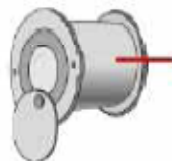

5 Door hinge broken

9 Security chain broken



6 Drawer handle broken



7 Cupboard handle broken

10 Postal flap broken

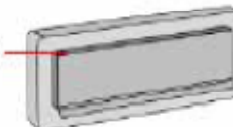

When reporting a repair, simply call our maintenance team on 020 8554 1009.

This information booklet has been produced to provide you with an ease of mind when reporting a repair.



Doors – Garages

What is the fault and it's number?

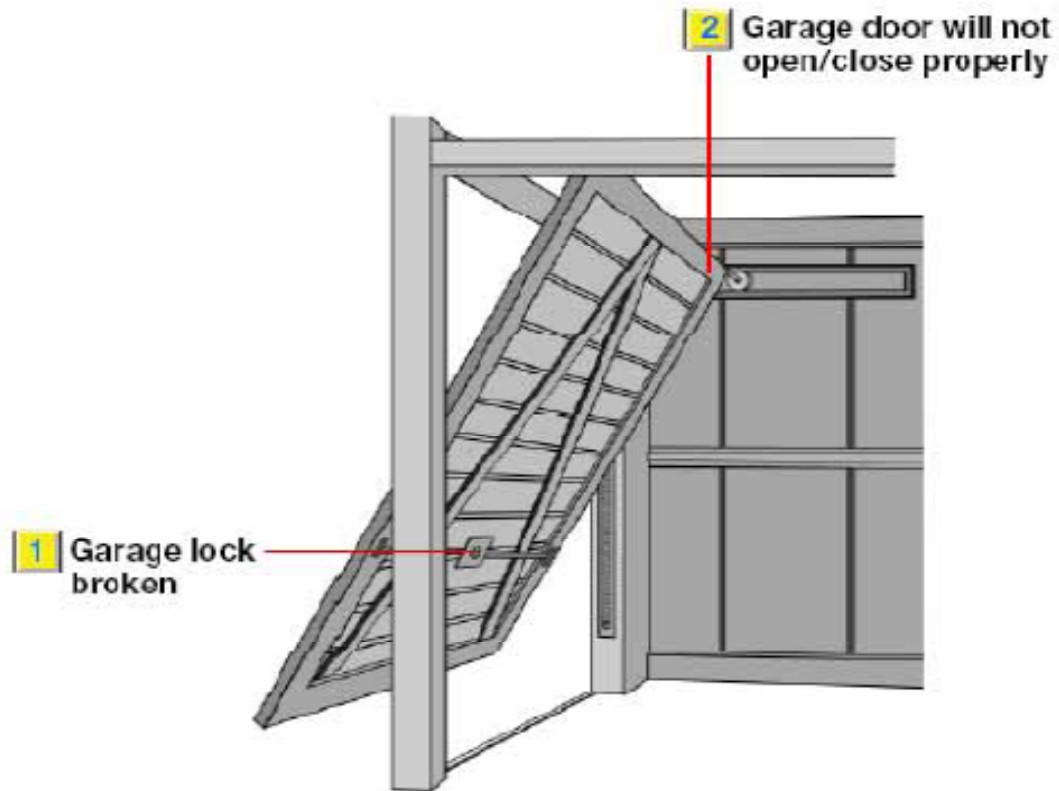

When reporting a repair, simply call our maintenance team on 020 8554 1009.

This information booklet has been produced to provide you with an ease of mind when reporting a repair.



Doors – Internal

What is the fault and it's number?

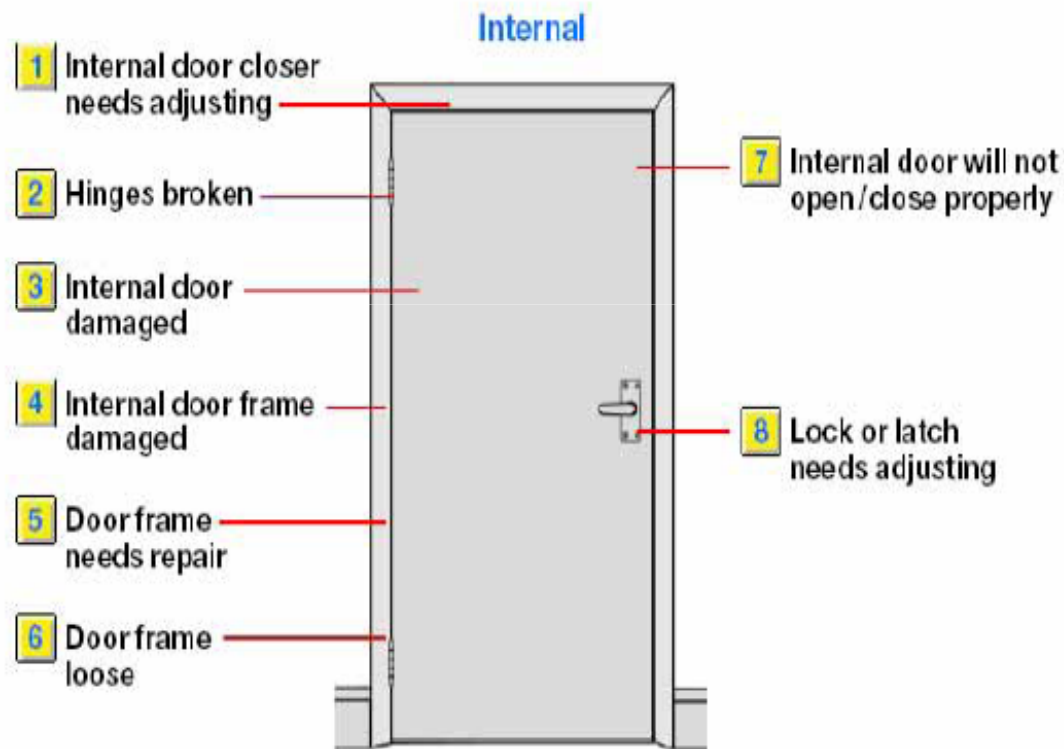

When reporting a repair, simply call our maintenance team on 020 8554 1009.

This information booklet has been produced to provide you with an ease of mind when reporting a repair.



Doors – Locks

What is the fault and it's number?

1 New cylinder needed for night latch (Yale type)

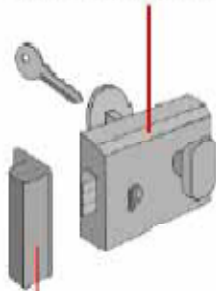

2 Mortice lock broken

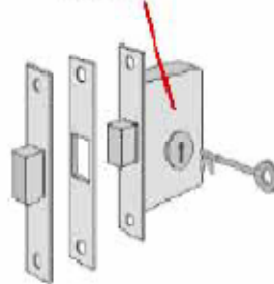

3 New cylinder needed for multi secure door

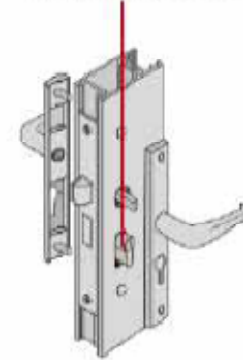

4 Night latch (Yale type) broken

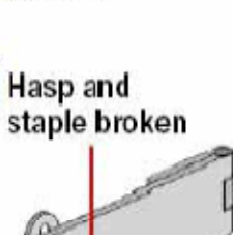

5 Hasp and staple broken

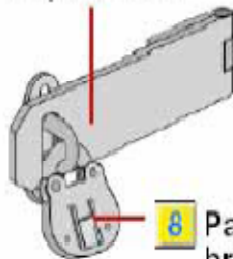

6 Padbolt broken

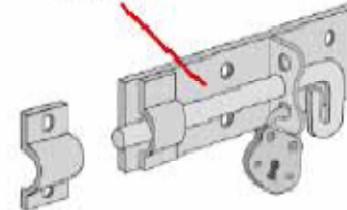

7 Bolt broken

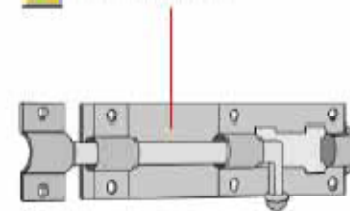

8 Padlock broken

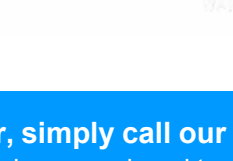

When reporting a repair, simply call our maintenance team on 020 8554 1009.

This information booklet has been produced to provide you with an ease of mind when reporting a repair.



Drainage

What is the fault and it's number?

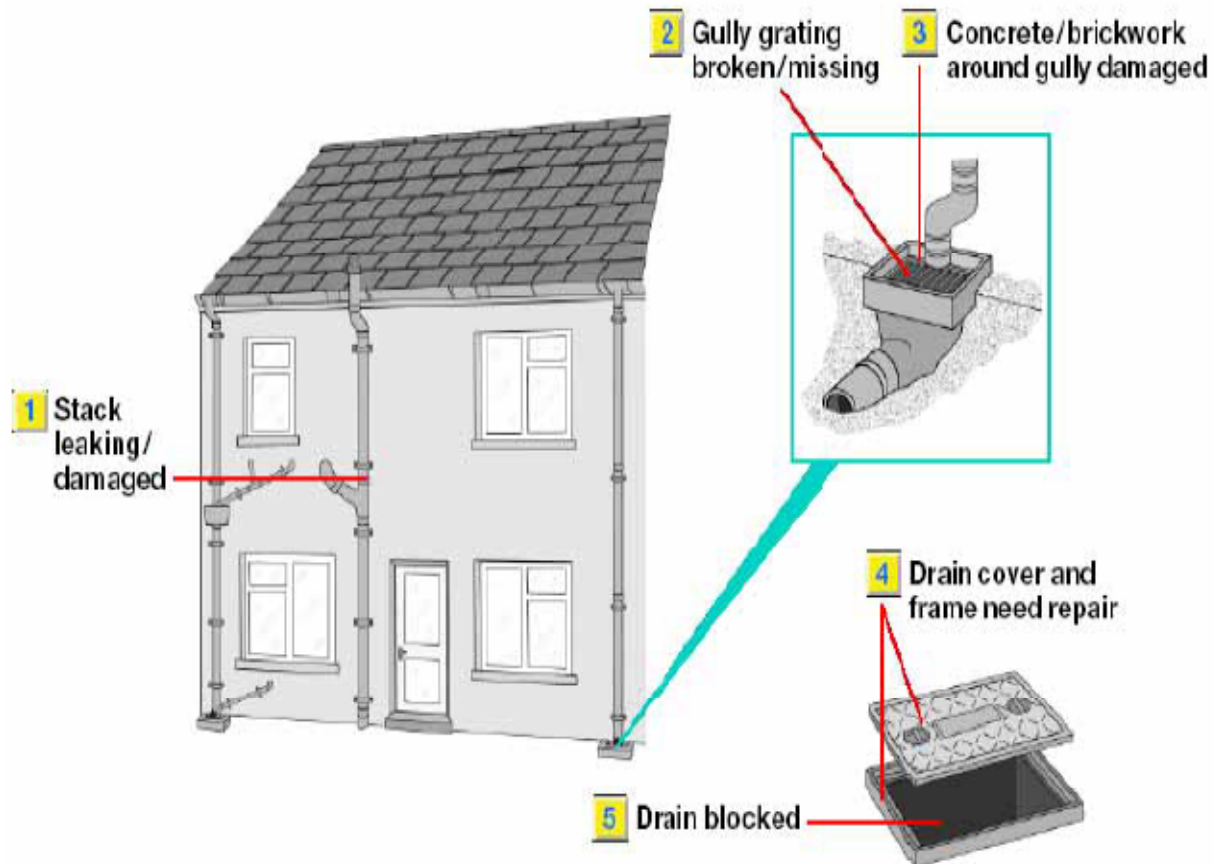

When reporting a repair, simply call our maintenance team on 020 8554 1009.

This information booklet has been produced to provide you with an ease of mind when reporting a repair.



Electrics

What is the fault and it's number?

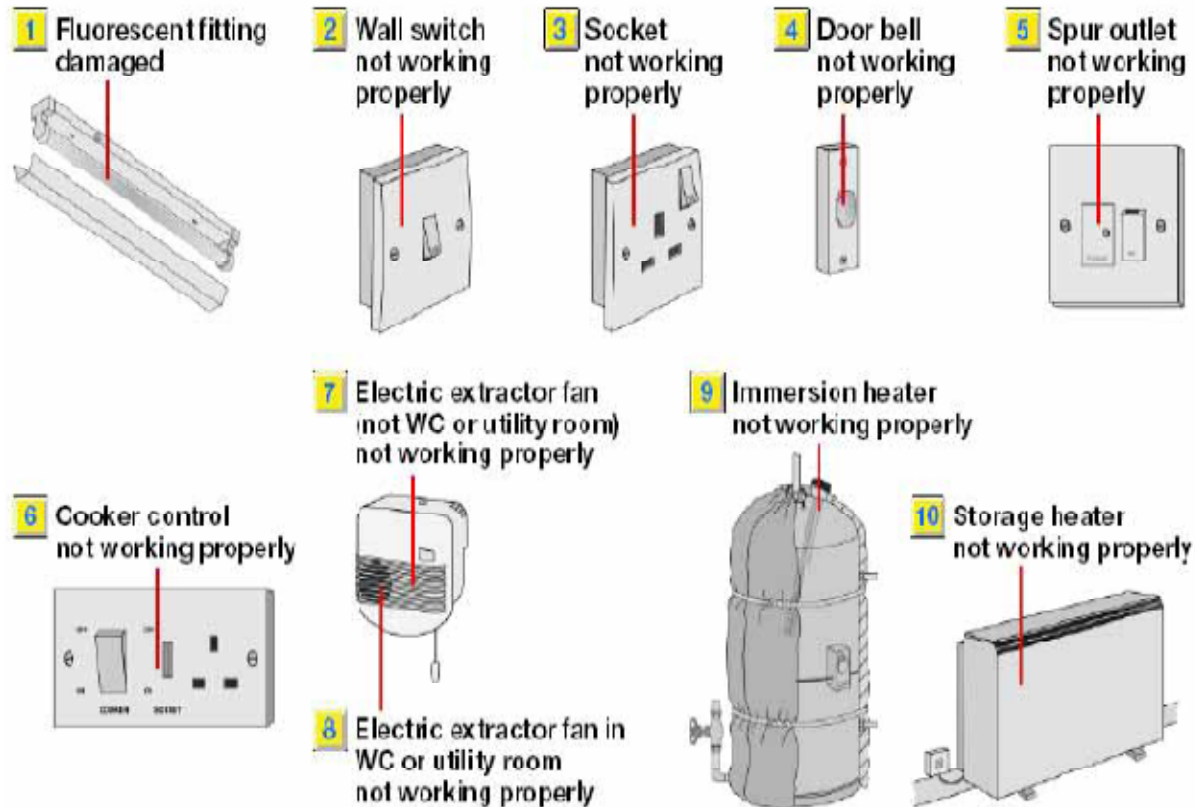

When reporting a repair, simply call our maintenance team on 020 8554 1009.

This information booklet has been produced to provide you with an ease of mind when reporting a repair.



Externals

What is the fault and it's number?

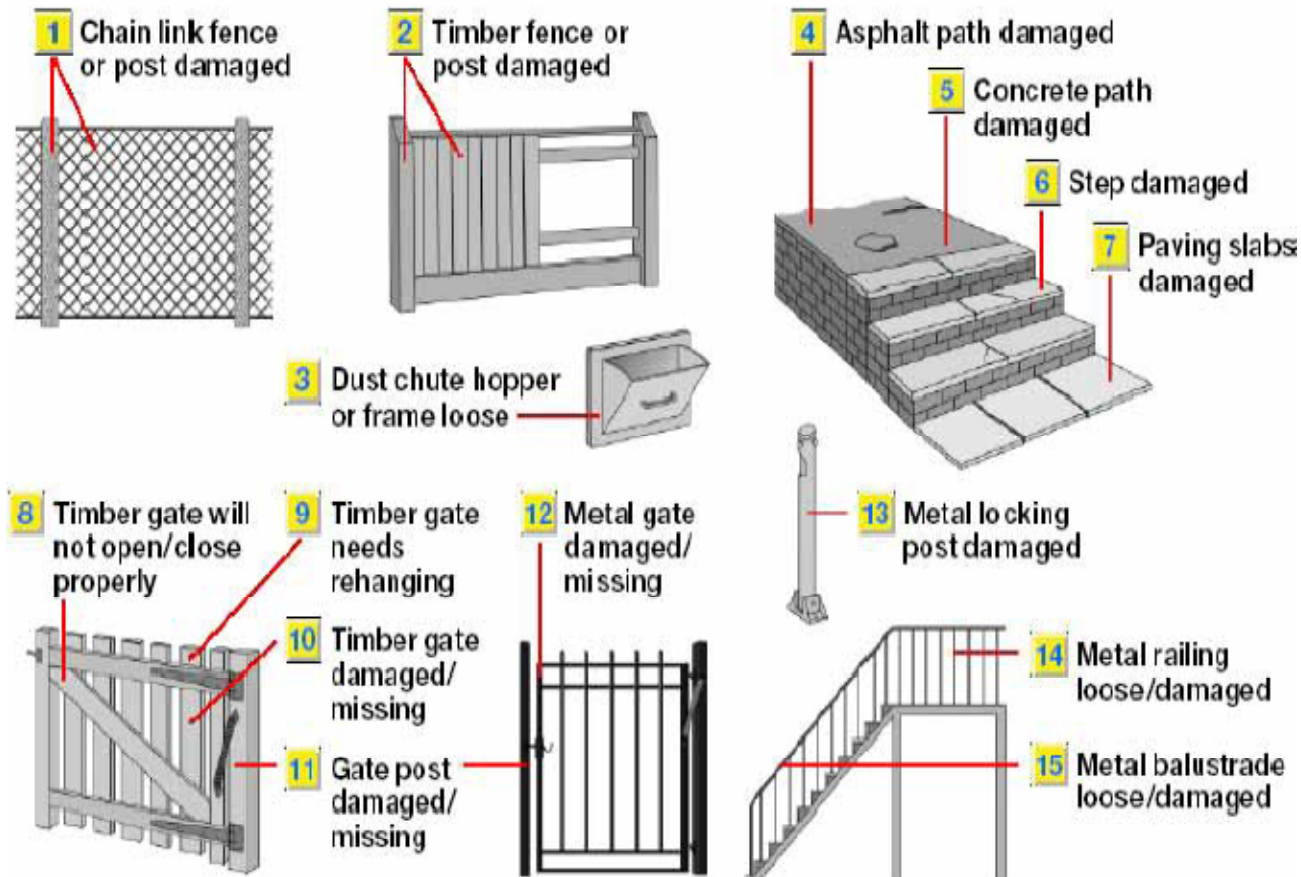

When reporting a repair, simply call our maintenance team on 020 8554 1009.

This information booklet has been produced to provide you with an ease of mind when reporting a repair.



Floors, Walls and Ceilings

What is the fault and it's number?

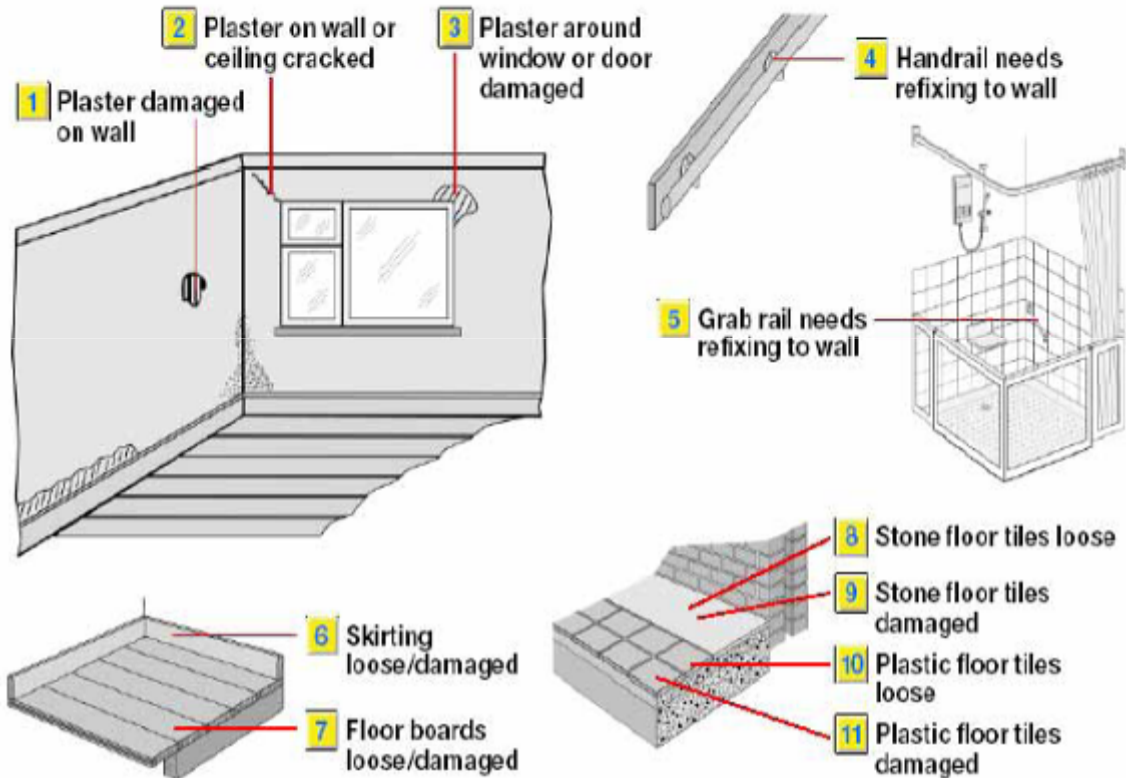

When reporting a repair, simply call our maintenance team on 020 8554 1009.

This information booklet has been produced to provide you with an ease of mind when reporting a repair.



Glazing

What is the fault and it's number?

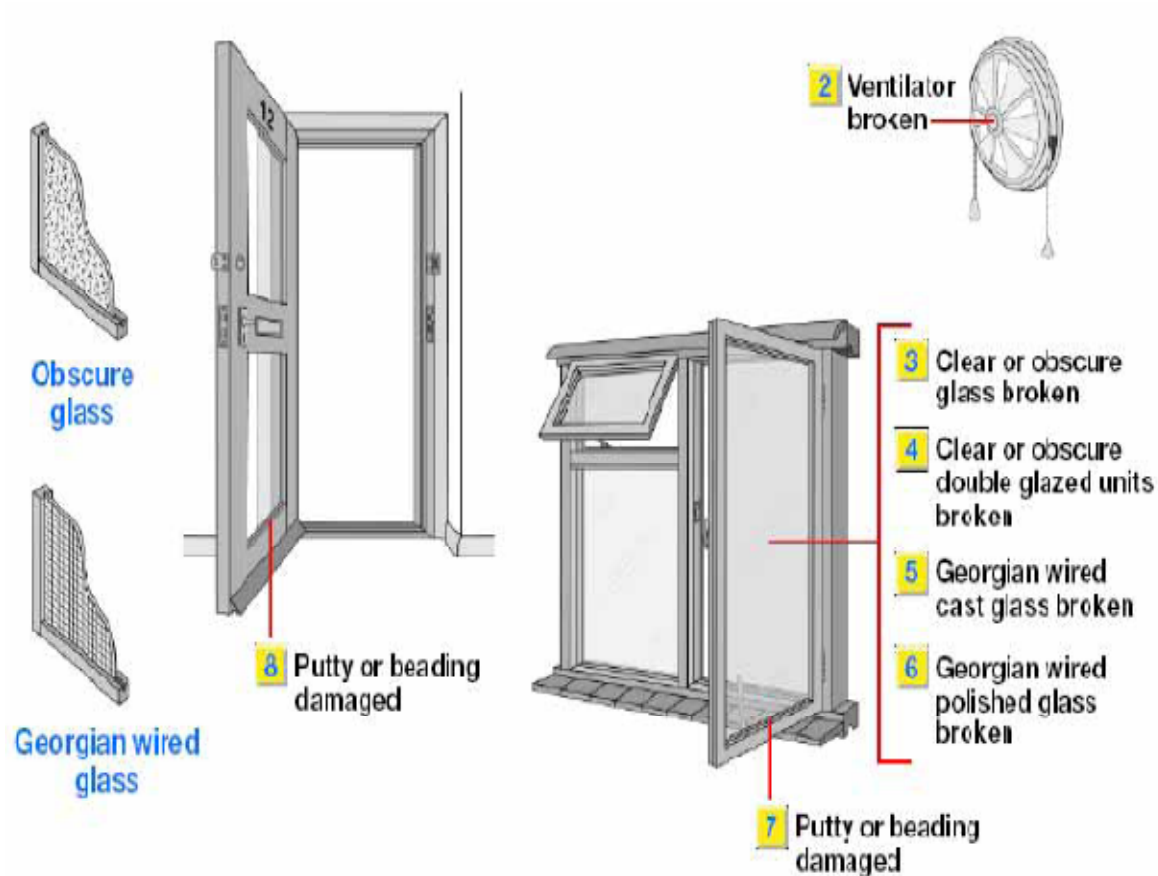

When reporting a repair, simply call our maintenance team on 020 8554 1009.

This information booklet has been produced to provide you with an ease of mind when reporting a repair.



Gutters

What is the fault and it's number?

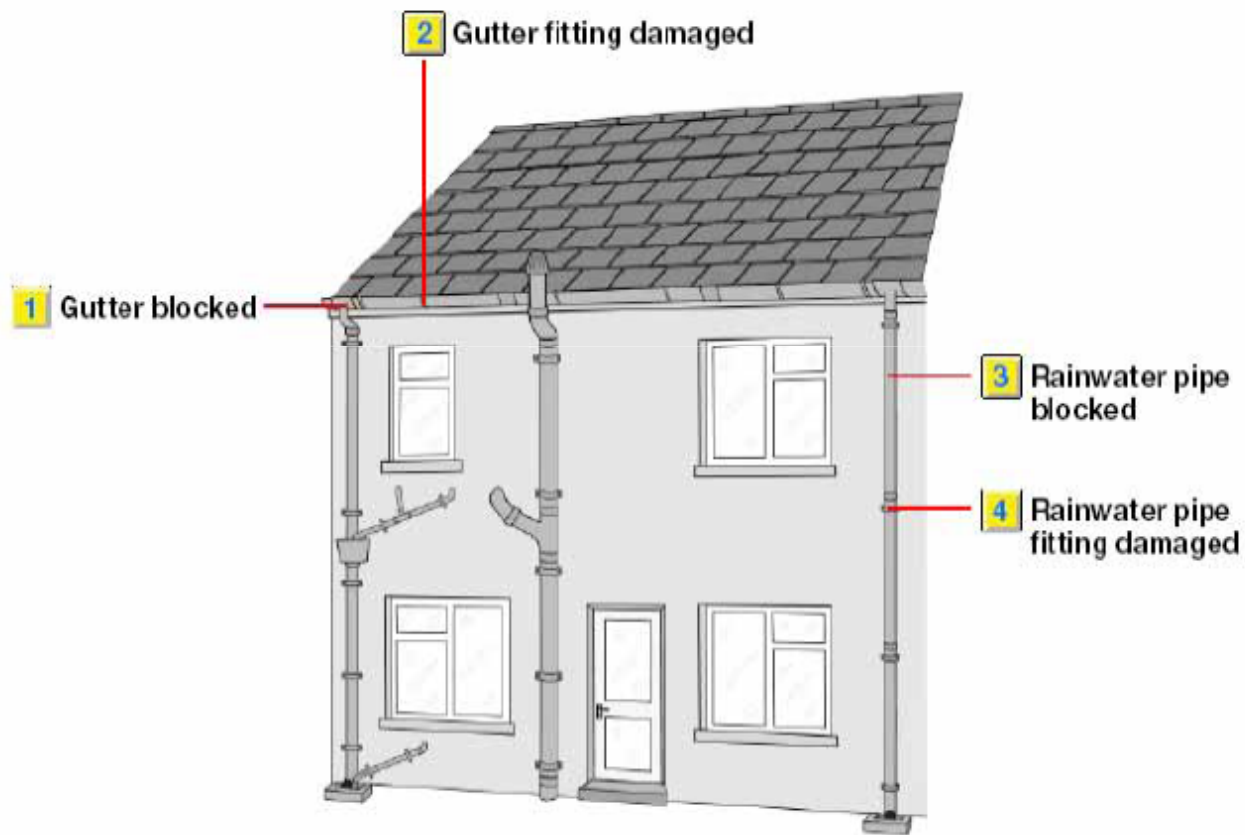

When reporting a repair, simply call our maintenance team on 020 8554 1009.

This information booklet has been produced to provide you with an ease of mind when reporting a repair.



Heating and Hot Water

What is the fault and it's number?

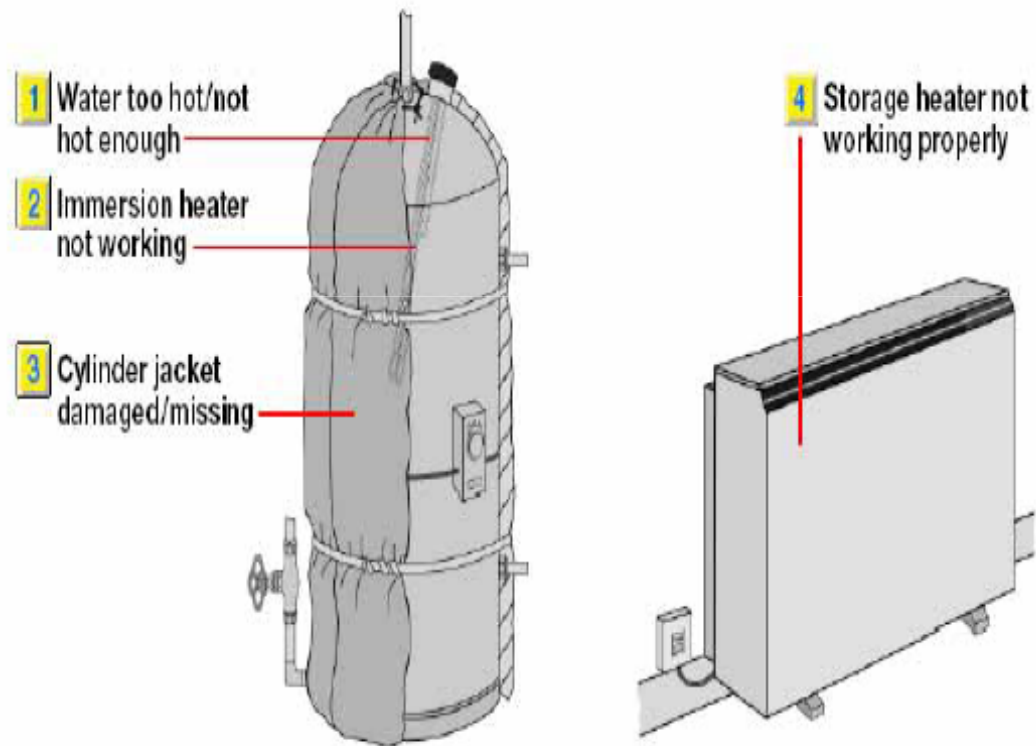

When reporting a repair, simply call our maintenance team on 020 8554 1009.

This information booklet has been produced to provide you with an ease of mind when reporting a repair.



Kitchen Units

What is the fault and it's number?

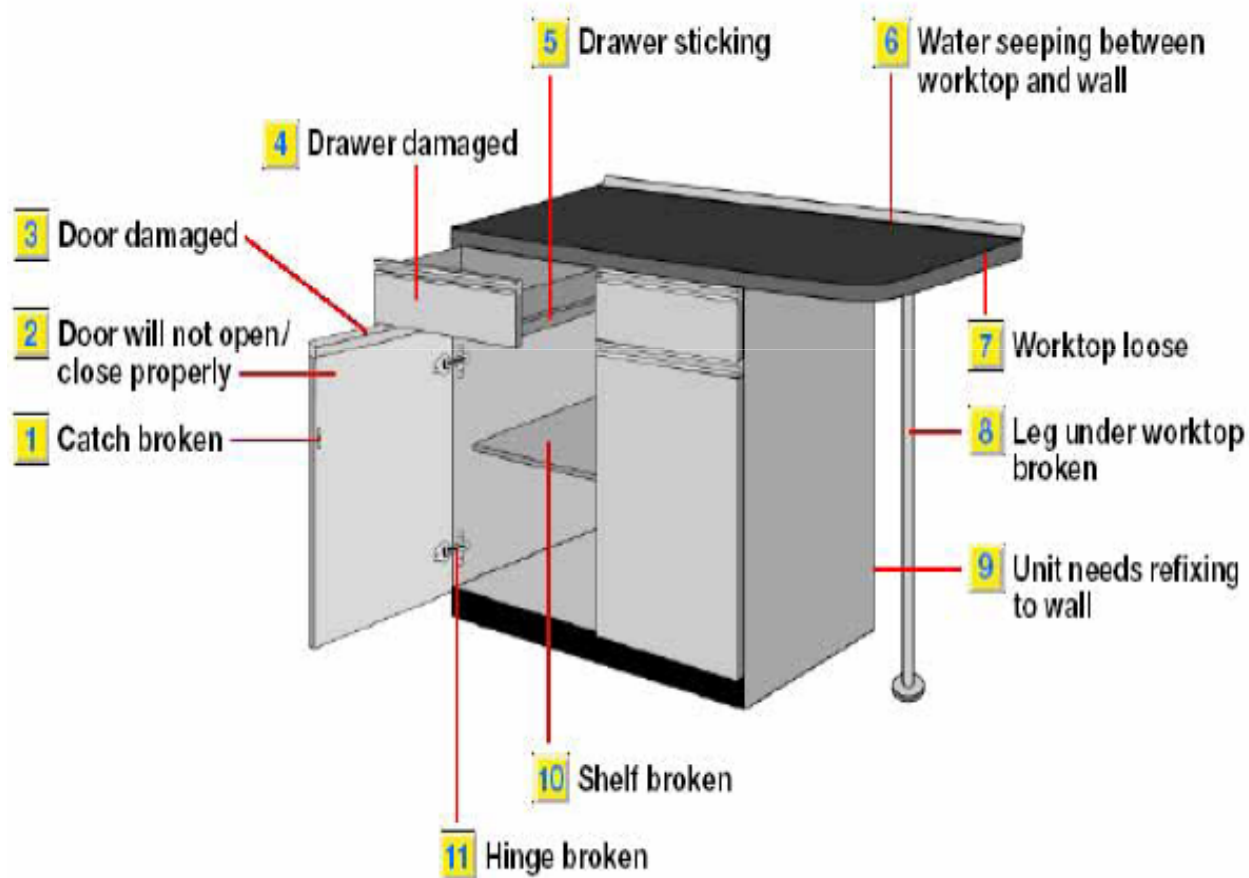

When reporting a repair, simply call our maintenance team on 020 8554 1009.

This information booklet has been produced to provide you with an ease of mind when reporting a repair.



Roofing

What is the fault and it's number?

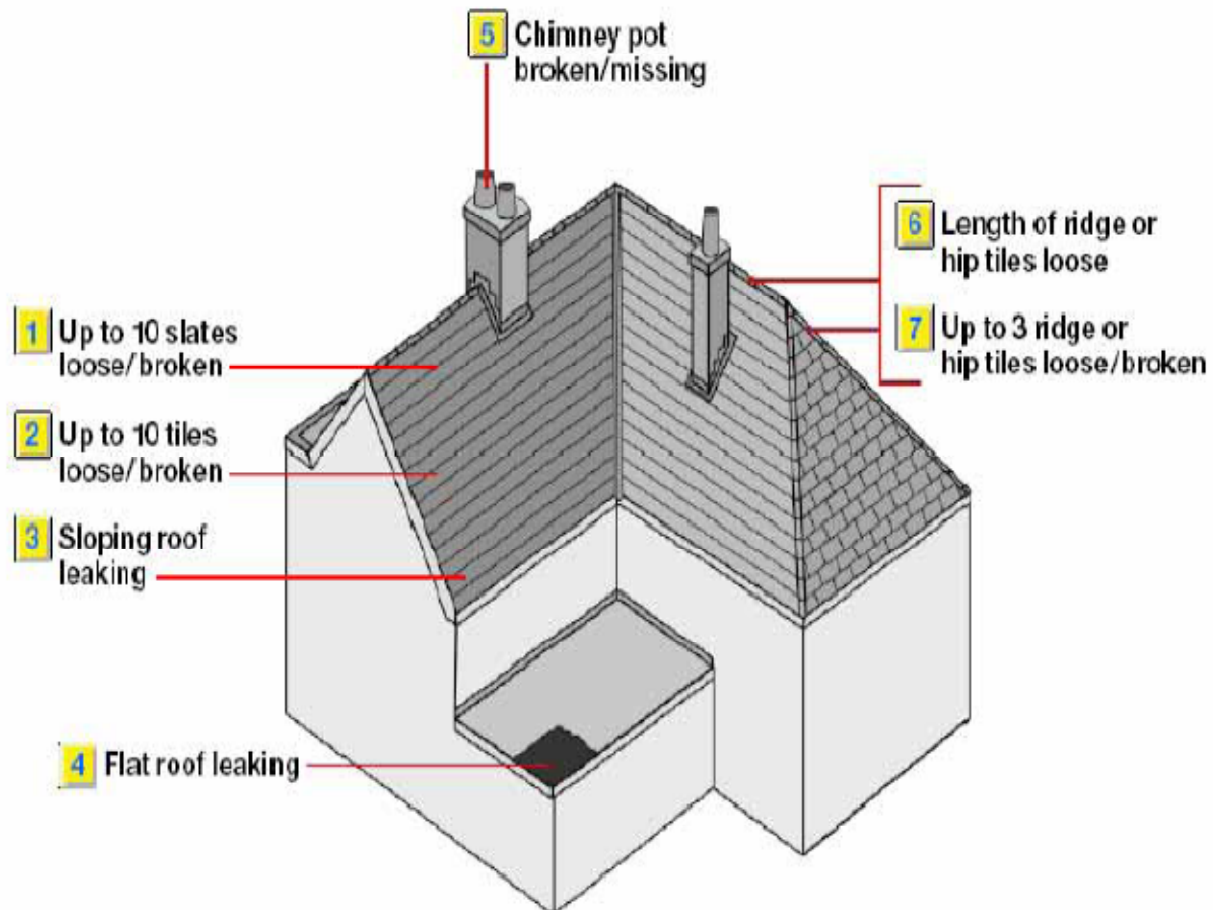

When reporting a repair, simply call our maintenance team on 020 8554 1009.

This information booklet has been produced to provide you with an ease of mind when reporting a repair.



Sinks and Basin

What is the fault and it's number?

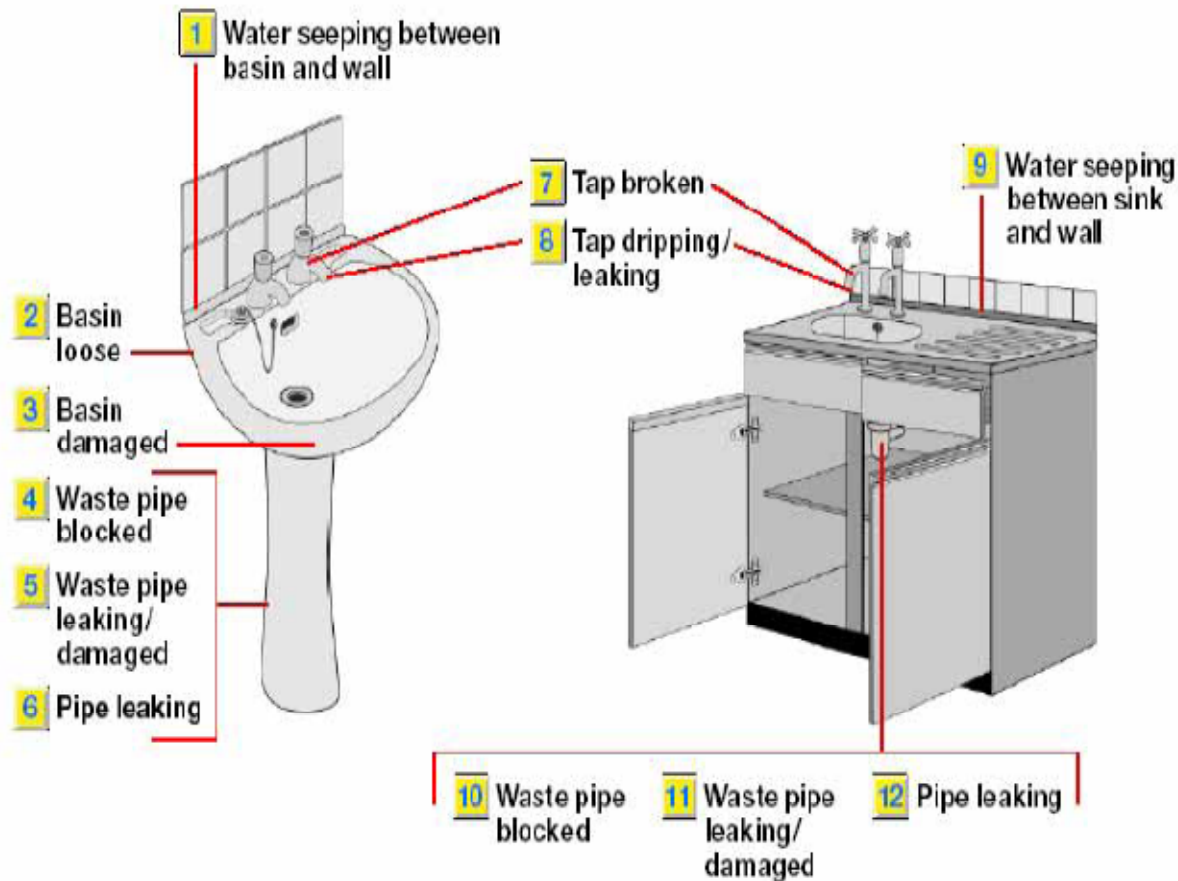

When reporting a repair, simply call our maintenance team on 020 8554 1009.

This information booklet has been produced to provide you with an ease of mind when reporting a repair.



Stairs

What is the fault and it's number?

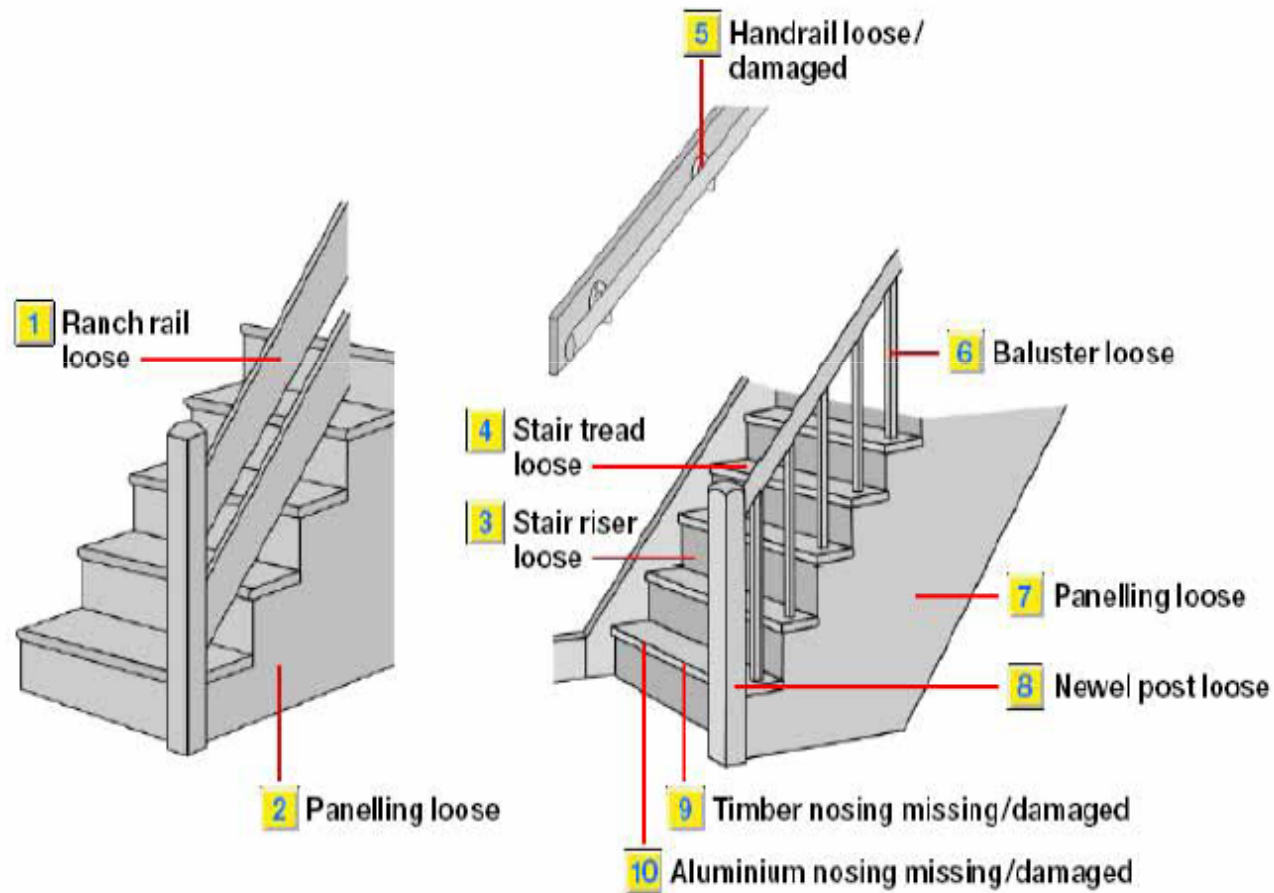

When reporting a repair, simply call our maintenance team on 020 8554 1009.

This information booklet has been produced to provide you with an ease of mind when reporting a repair.



Toilets

What is the fault and it's number?

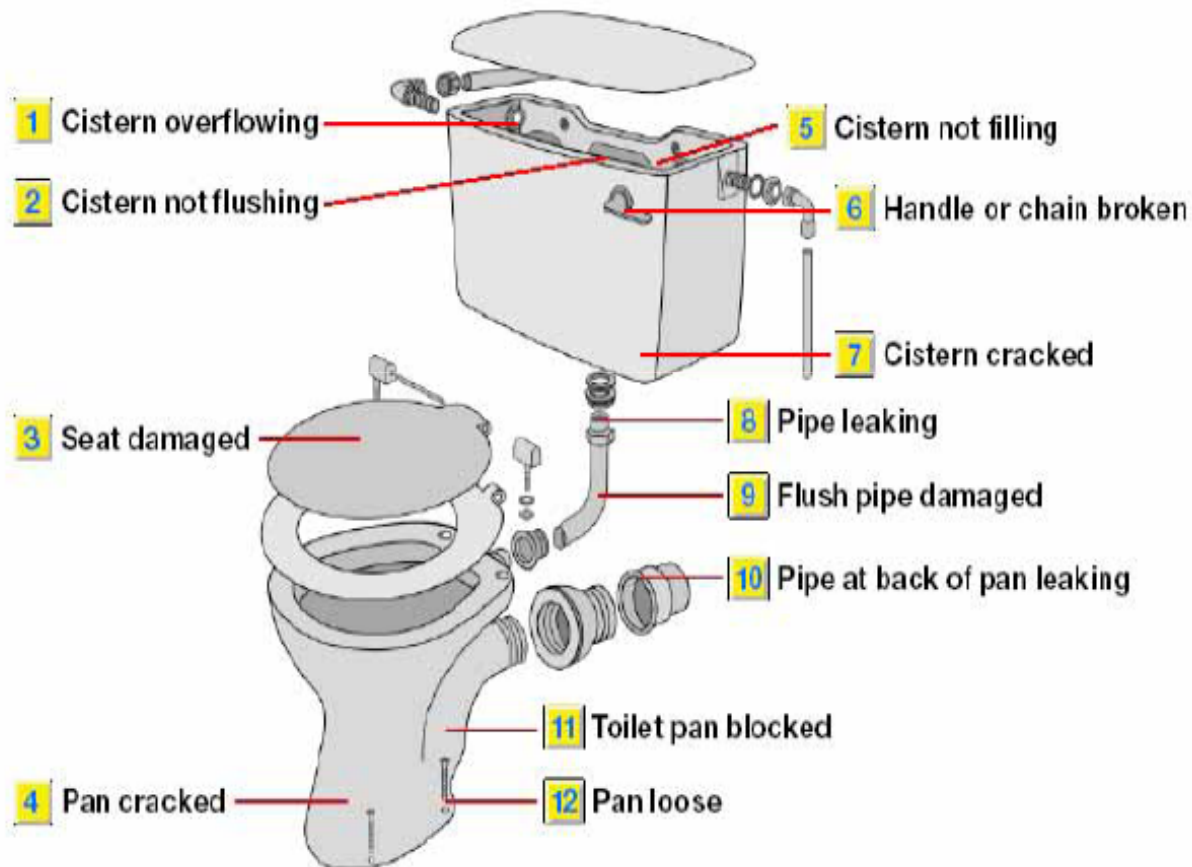

When reporting a repair, simply call our maintenance team on 020 8554 1009.

This information booklet has been produced to provide you with an ease of mind when reporting a repair.



Water Services

What is the fault and it's number?

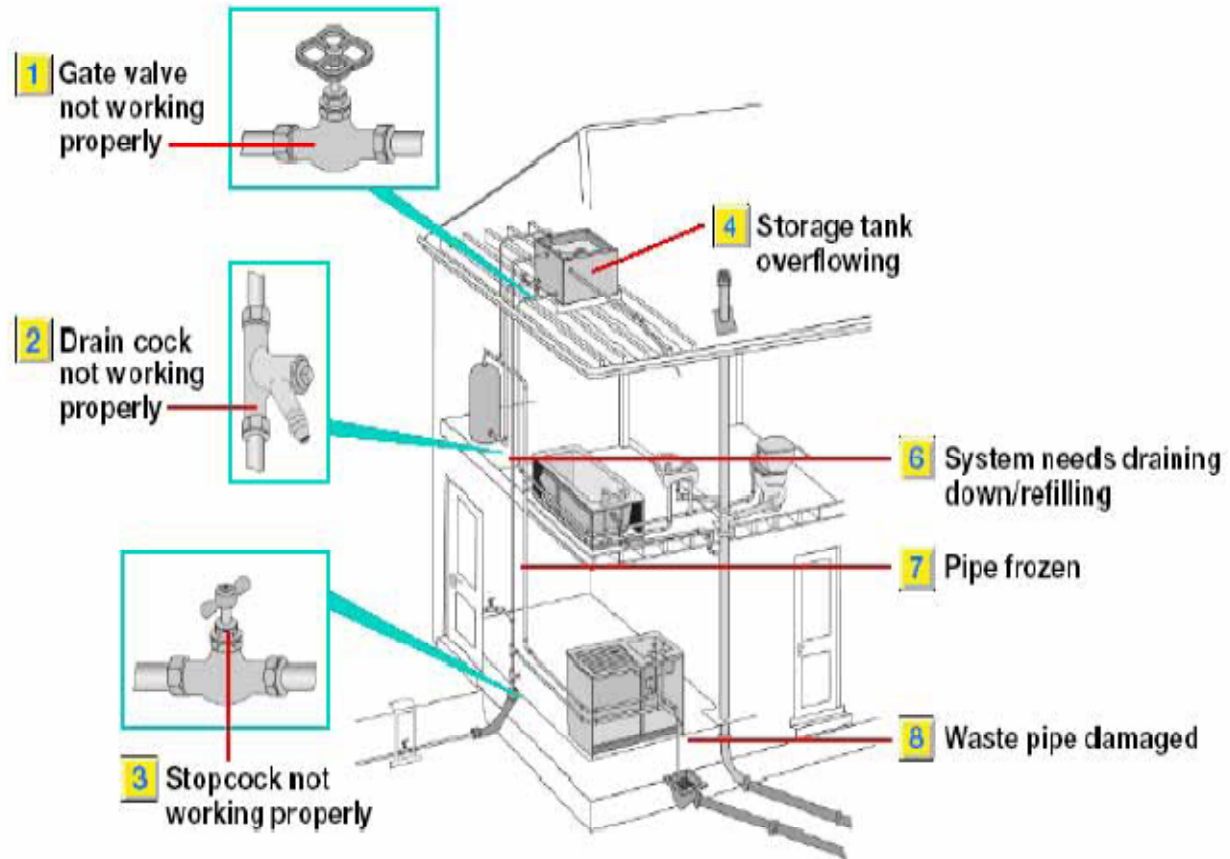

When reporting a repair, simply call our maintenance team on 020 8554 1009.

This information booklet has been produced to provide you with an ease of mind when reporting a repair.



Windows - Timber

What is the fault and it's number?

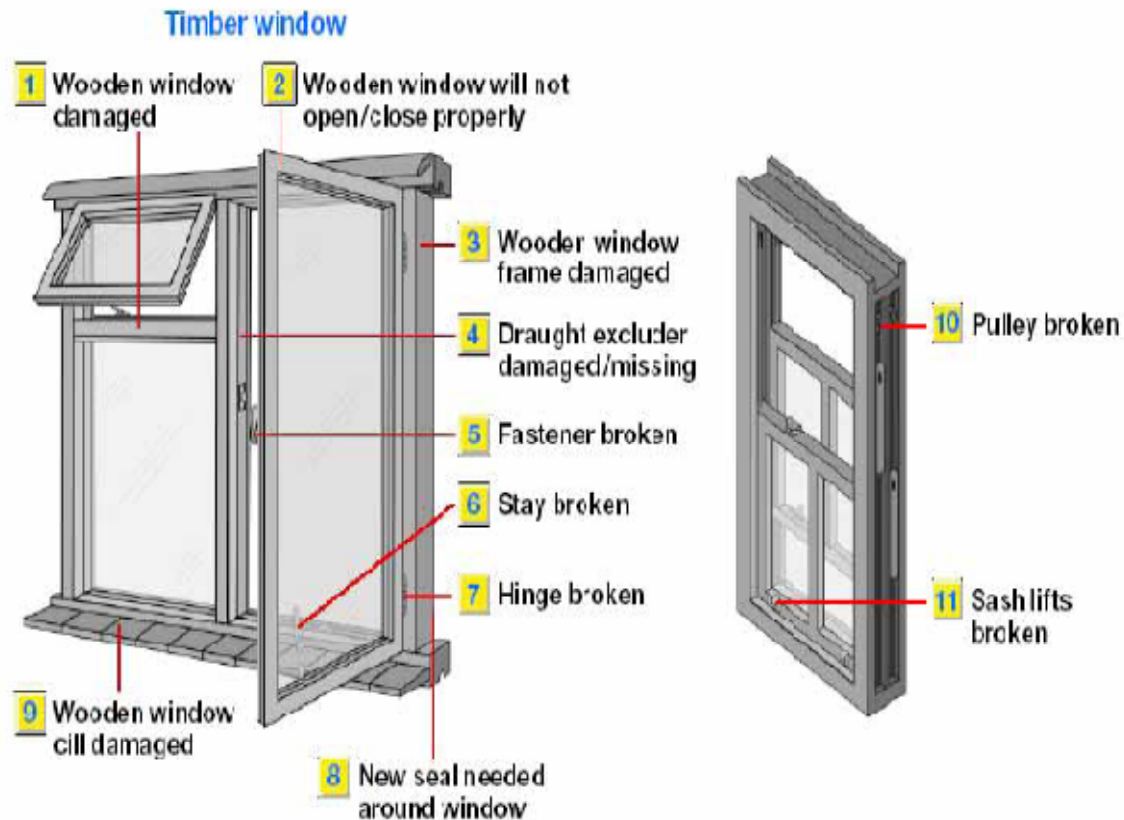

When reporting a repair, simply call our maintenance team on 020 8554 1009.

This information booklet has been produced to provide you with an ease of mind when reporting a repair.



Windows - Metal

What is the fault and it's number?

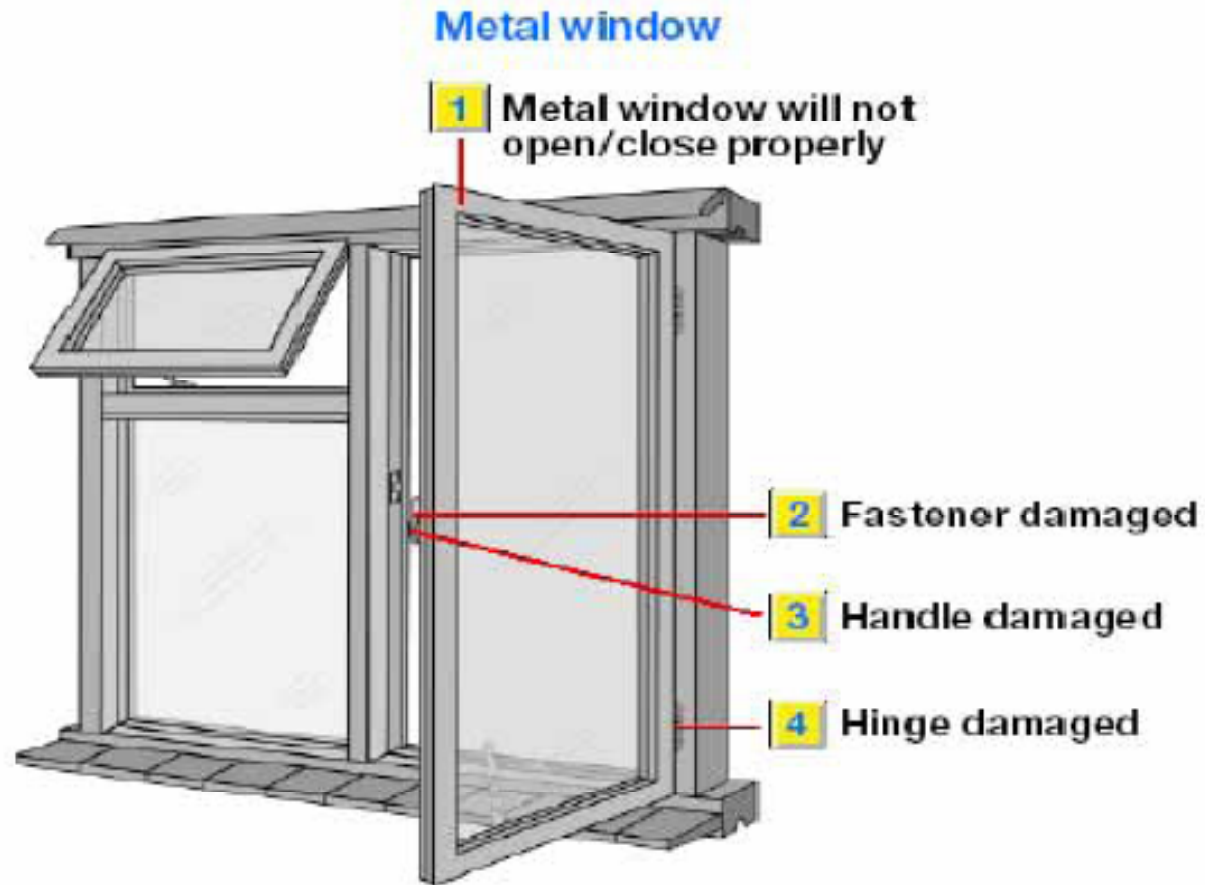

When reporting a repair, simply call our maintenance team on 020 8554 1009.

This information booklet has been produced to provide you with an ease of mind when reporting a repair.



Windows – UPVC/Aluminium

What is the fault and it's number?

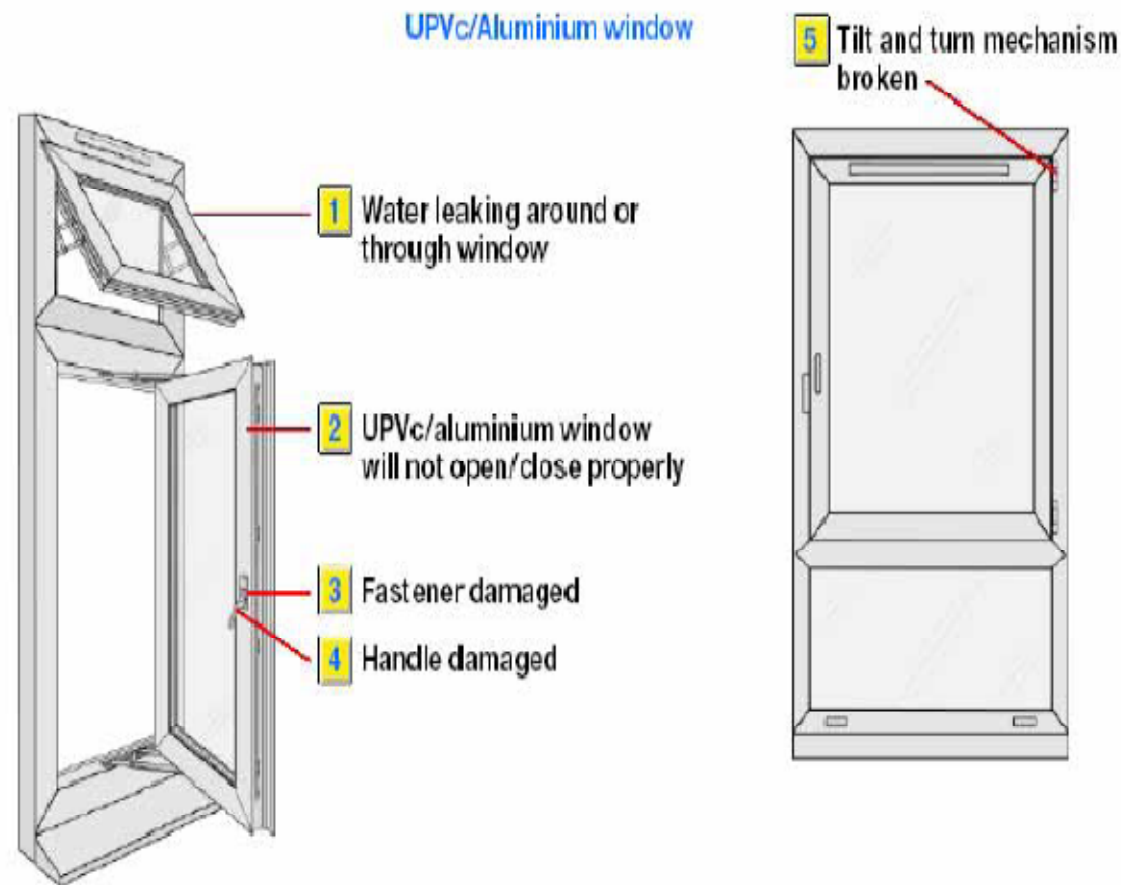

When reporting a repair, simply call our maintenance team on 020 8554 1009.

This information booklet has been produced to provide you with an ease of mind when reporting a repair.

